

Clarke®



PRESSURE TEST PUMP

MODEL NO: PTP100

PART NO: 5060205

USER INSTRUCTIONS

ORIGINAL INSTRUCTIONS

GC0324 - Rev 3

INTRODUCTION

Thank you for purchasing this CLARKE Pressure Testing Pump.

Before attempting to use the product it is essential that you read this manual thoroughly and carefully follow all instructions given. In doing so you will ensure the safety of yourself and that of others around you and you can also look forward to the product giving you long and satisfactory service.

Please keep these instructions in a safe place for future reference.

SPECIFICATION

Dimensions (D x W x H)	528 x 220 x 320 mm
Weight	7 kg
Reservoir capacity	10 L
Pressure	50 bar / 5 MPa / 725 psi
Stroke volume	40 cm ³
Gauge max	60 bar (870 psi)

GUARANTEE

This product is guaranteed against faulty manufacture for a period of 12 months from the date of purchase. Please keep your receipt which will be required as proof of purchase.

This guarantee is invalid if the product is found to have been abused or tampered with in any way, or not used for the purpose for which it was intended.

Faulty goods should be returned to their place of purchase, no product can be returned to us without prior permission.

This guarantee does not effect your statutory rights.

ENVIRONMENTAL RECYCLING POLICY

Do not dispose of this product with general household waste. All tools, accessories and packaging should be sorted, taken to a recycling centre and disposed of appropriately.

OVERVIEW

This Pressure Testing Pump is primarily intended for the pressure testing of new heating installations prior to the connection to the boiler and for fault-finding of leaks and identifying air ingress problems on existing systems.

When correctly connected to a pipeline/radiator network or complete central heating system, this hand operated unit is used to build up the required hydraulic pressure. The reservoir incorporates a filter to prevent dirt entering the system under test and the gauge is shielded to prevent damage.

It may not be suitable for testing domestic low pressure domestic heating systems which typically operate between 1.0 to 2.5 bar.

It can also be used for quick and exact pressure testing of installations such as compressed air and refrigeration systems and small bore pipelines. However, it is unsuitable for testing gas systems since liquid must be used.

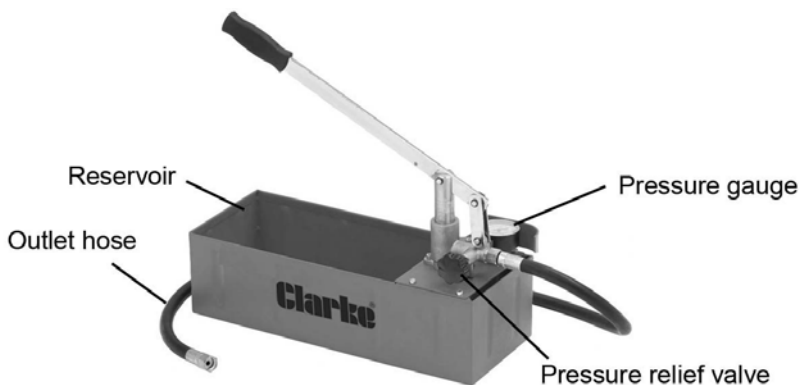

PARTS SUPPLIED

When unpacking, check for damage and /or shortages etc. Any found should be reported to your CLARKE dealer where the pump was originally purchased. This Pressure testing pump should include the following:

- 1 x Pressure testing pump assembly
- 1 x Locking pin & chain
- 2 x Sealing washers (O-rings)
- 1 x High pressure hose

GENERAL SAFETY RULES



WARNING: AS WITH ALL EQUIPMENT, THERE ARE CERTAIN HAZARDS INVOLVED WITH THE USE AND OPERATION OF THIS PRODUCT. EXERCISING CAUTION WILL REDUCE THE RISK OF PERSONAL INJURY.

1. **ALWAYS** thoroughly familiarise yourself with this product and its operation, and follow all instructions in this manual.
2. **ALWAYS** ensure that the pump is properly positioned where necessary to prevent it from moving during operation, and that the immediate area surrounding the pump is kept clear.
3. **ALWAYS** use only replacement parts supplied by the manufacturer. The use of non standard parts could be hazardous.
4. **ALWAYS** ensure that any residual pressure has been relieved before performing any maintenance.
5. **ALWAYS** use only piping, hose and fittings rated equal to or greater than the maximum PSI rating of the pump.
6. **ALWAYS** maintain the equipment in good /clean condition for the best/ safest performance.
7. **ALWAYS** wear eye protection when working with pressurised systems.
8. **ALWAYS** return any systems that has been sealed off for testing to their original state before the system can be used again.
9. **ALWAYS** wash your hands thoroughly after handling used oil.
10. **NEVER** exceed the recommended testing pressure for any water heating system or component within that system.
11. **NEVER** use this pressure tester for tasks it is not designed to perform.
12. **NEVER** use this product if it is damaged.
13. **ALWAYS** establish the correct testing pressure for the pipework/installation to be tested before attempting to pressurise the system.
14. **NEVER** allow children to use this product.
15. **NEVER** attempt any repairs to this appliance.
16. **NEVER** throw away used oil with domestic refuse or flush down a sink or drain. Collect any old oil in a leakproof container and take it to you local waste disposal site.
17. If necessary, have the pump repaired by a qualified person using identical replacement parts to ensure that the safety of the product is maintained.

USING THE PRESSURE TEST PUMP

POINTS TO CONSIDER

1. If you are not a trained plumber or heating engineer, seek professional guidance on the correct use of this equipment in conjunction with the system to be tested.
2. Establish the correct test pressure for the installation to be tested by referring to the system specification and /or the manufacturer's recommendations. Given that each pump stroke can produce approx 20 bar of pressure, take care not to over-pressurise the system under test.
3. Ensure the heating system is fully OFF before commencing testing.
4. Any system to be tested must be fully sealed off in order for the test pressure to build up. When testing is finished, the system must be returned to its original design state before it can be used again.
5. If the system includes pressure relief valves, these must be temporarily disabled if the system is to be tested at more than their pre-set relief pressure. After testing, the pressure relief valves must be re-activated.
6. The system to be tested must be fully filled with water throughout and the test pressure built up.

BEFORE USE

1. Check the condition of the hose and ensure all connections are tight and secure. Remove the locking pin to allow full movement of the arm/pivot assembly.
2. Connect the pressure hose to the pump outlet and the other end to the system to be tested. A suitable point on the system will need to be chosen and if necessary, an adaptor used to connect the pump outlet hose to the fluid system.



CAUTION: NEVER EXCEED THE RECOMMENDED TESTING PRESSURE FOR ANY WATER HEATING SYSTEM OR COMPONENT WITHIN THAT SYSTEM.

3. Ensure there is sufficient clean liquid in the reservoir to cover the inlet pipe and then close the pressure relief valve.
4. Pump the handle until the pressure gauge indicates the desired pressure has been reached. If the required pressure is exceeded, reduce it by twisting the release valve as required. Allow the unit to stabilise for 15-30 seconds.

5. If the system is free from leaks, the pressure shown on the gauge will not drop during the test period. If the pressure is being lost, there is a leak in the system and a visual inspection should be made to locate the leak.
6. After testing, open the relief valve to release all pressure and allow water to flow back into the reservoir before disconnecting the pump from the tested system and re-sealing the point of connection.
7. Where the system has been temporarily sealed for testing, ensure the system is returned to its original condition.

TYPICAL SYSTEM LAYOUT

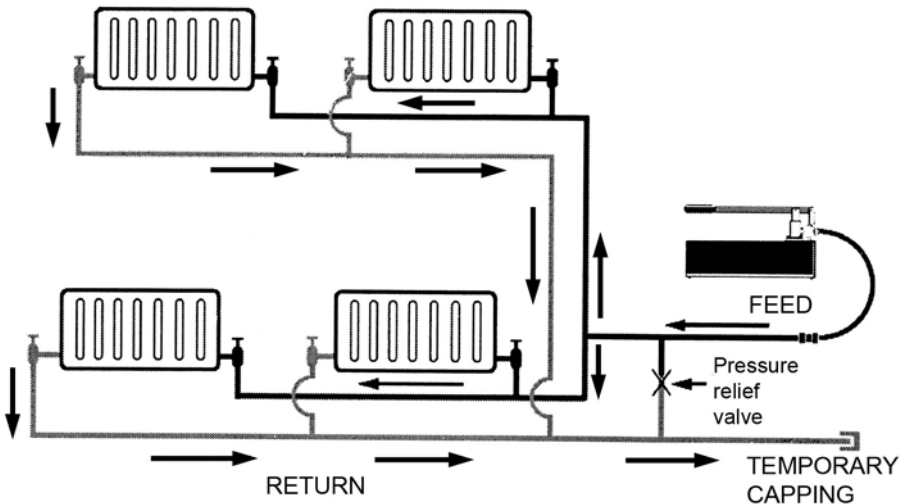

COMPONENT PARTS

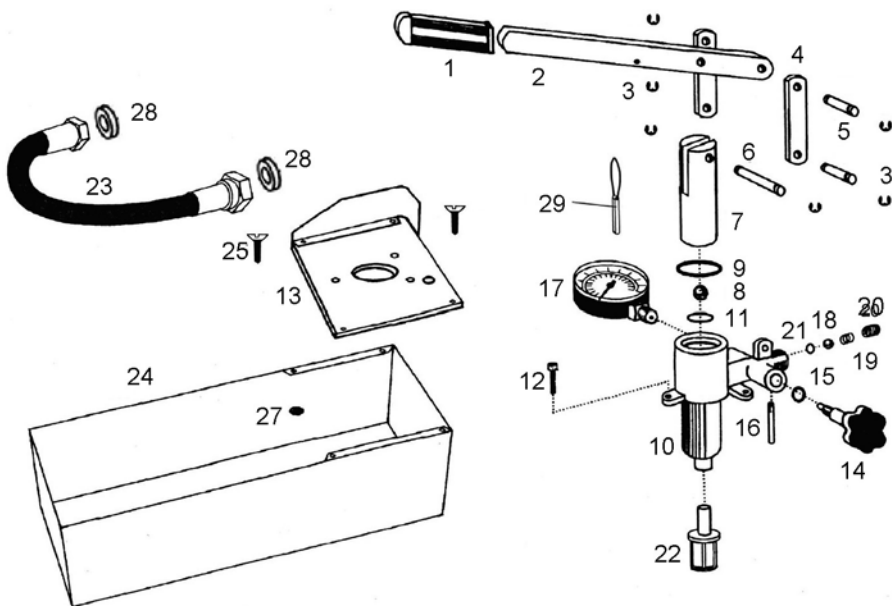

No	Description	Qty
1	Handle grip	1
2	Handle	1
3	Circlip	6
4	Drop arm	2
5	Spindle	2
6	Axle	1
7	Piston	1
8	Steel ball	1
9	Airtight gasket	1
10	Casting body	1
11	Airtight gasket	1
12	M6 x 20 screw	1
13	Cover plate	5
14	Relief valve	1

No	Description	Qty
15	O-ring seal	1
16	Connecting tube	1
17	Pressure gauge	1
18	Steel ball	1
19	Spring	1
20	Screw plug	1
21	O-ring seal	1
22	Oil filter	1
23	Oil hose	1
24	Reservoir	1
25	M6 x 16 screw	5
26	Pin and chain	1
27	Nut	7
28	O-ring	2

A SELECTION FROM THE VAST RANGE OF

Clarke®

QUALITY PRODUCTS



AIR COMPRESSORS

From DIY to industrial, Plus air tools, spray guns and accessories.

GENERATORS

Prime duty or emergency standby for business, home and leisure.

POWER WASHERS

Hot and cold, electric and engine driven - we have what you need

WELDERS

Mig, Arc, Tig and Spot. From DIY to auto/industrial.

METALWORKING

Drills, grinders and saws for DIY and professional use.

WOODWORKING

Saws, sanders, lathes, mortisers and dust extraction.

HYDRAULICS

Cranes, body repair kits, transmission jacks for all types of workshop use.

WATER PUMPS

Submersible, electric and engine driven for DIY, agriculture and industry.

POWER TOOLS

Angle grinders, cordless drill sets, saws and sanders.

STARTERS/CHARGERS

All sizes for car and commercial use.



PARTS & SERVICE: 0208 988 7400

Parts Enquiries
Parts@clarkeinternational.com

Servicing & Technical Enquiries
Service@clarkeinternational.com

SALES: UK 01992 565333 or Export 00 44 (0)1992 565335

Clarke INTERNATIONAL Hemnall Street, Epping, Essex CM16 4LG
www.clarkeinternational.com